

WOJ-WOJK axiális fali ventilátorok

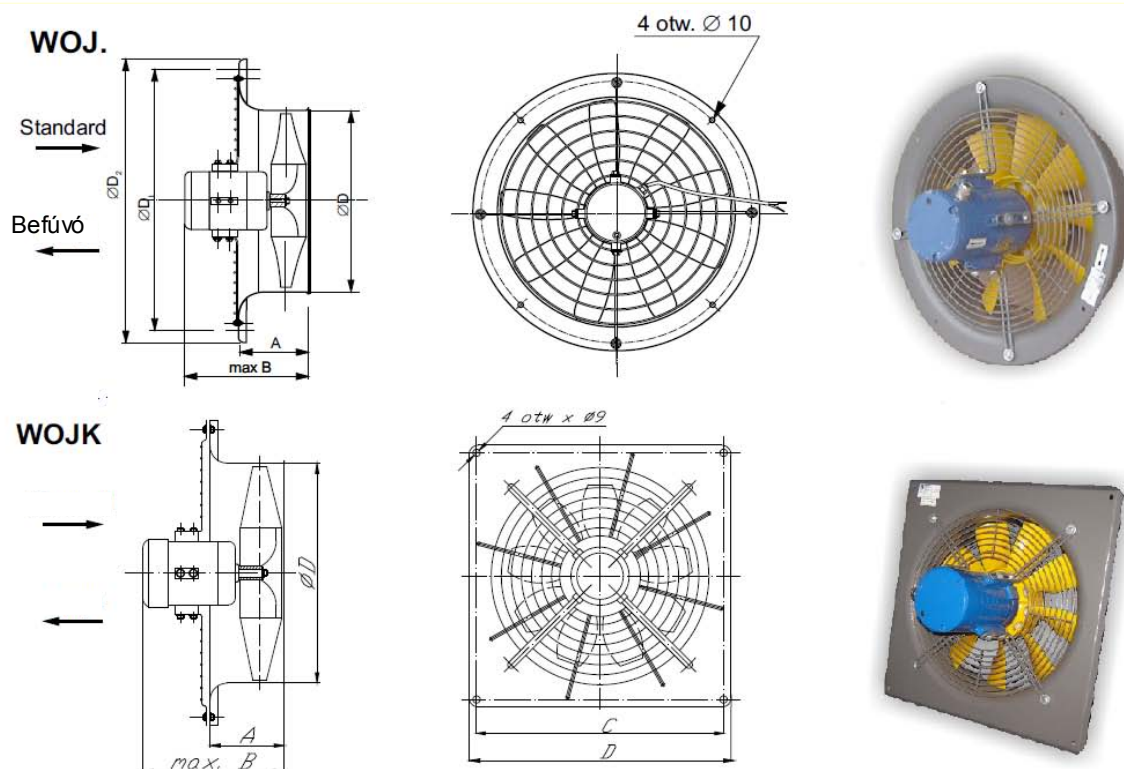

Typ	A	B	ØD	C	D	Masa
	[mm]	[mm]	[mm]	[mm]	[mm]	[kg]
WOJK-31	130	300	315	360	410	13
WOJK-35	130	310	355	400	450	14
WOJK-40	130	340	400	490	530	14
WOJK-45	140	390	450	520	580	15
WOJK-50	140	400	500	560	610	19
WOJK-56	190	400	560	620	700	22

Typ	A	B	ØD	ØD ₁	ØD ₂	Masa
	[mm]	[mm]	[mm]	[mm]	[mm]	[kg]
WOJ-31	110	295	315	400	440	10
WOJ-35	120	285	355	440	480	12
WOJ-40	130	310	400	490	530	14
WOJ-50	140	320	500	603	650	16
WOJ-56	180	380	560	685	730	19

Typ	Wydajność MAX	Wydajność nominalna V		Spręż. nom.	Głośnieść*	Moc silnika	Ilość obrotów	Napięcie zasilania	Masa
	[m ³ /h]	[m ³ /s]	[m ³ /h]	Δpc [Pa]	[dB]	[kW]	[obr./min]	[V]	[kg]
WOJ-31	2808	0,7	2520	79	70	0,15/0,2*	1400	230;400	10
WOJ-35	4530	0,9	3240	25	72	0,25/0,2*	1400	230;400	12
WOJ-40	6084	1,5	5400	95	74	0,25/0,2*	1400	230;400	14
WOJ-50/M	6120	1,36	4490	43	65	0,2	900	400	16
WOJ-50	7956	1,6	5760	100	76	0,37	1400	230;400	16
WOJ-56/M	7040	1,4	5060	53	68	0,37	900	400	20
WOJ-56/2	11000	2,2	7920	130	75	0,55	1400	230;400	19
WOJ-56/3	11160	2,6	9360	138	76	0,75	1400	230;400	19
WOJ-56/4	13100	2,8	10080	158	76	1,1	1400	230;400	19
WOJK-31	2808	0,7	2520	79	74	0,15/0,2*	1400	230;400	13
WOJK-35	4530	0,9	3240	25	72	0,25/0,2*	1400	230;400	12
WOJK-40	6084	1,5	5400	95	74	0,25/0,2*	1400	230;400	14
WOJK-45	7350	1,7	6120	100	74	0,37	1400	230;400	15
WOJK-50/M	6350	1,27	4572	57	65	0,2	900	400	16
WOJK-50	7956	1,6	5760	100	76	0,37	1400	230;400	19
WOJK-56/M	7040	1,4	5060	53	68	0,37	900	400	21
WOJK-56/2	11000	2,2	7920	130	75	0,55	1400	230;400	19
WOJK-56/3	11160	2,6	9360	138	76	0,75	1400	230;400	19
WOJK-56/4	13100	2,8	10080	158	76	1,1	1400	230;400	19
WOJK-80	28800	6	21600	115	74	0,75	900	400	59

